

**V A L V E**

**2- and 3-POINT Ball Valves Actuator 4.20N**

**Application**

The electric actuators of the JOVENTA VALVE series have been designed for operating ball valves.

The actuators are to be mounted with the linkage kit ZAK2 onto Joventa JV... series ball valves.

**Key features**

- 2- or 3-point control
- Load-independent running time
- Up to 5 actuators in parallel operation possible
- Plug-in terminal block connection
- Simple mount with ball valves adapter ZAK2
- Selectable direction of rotation
- Manual release button
- 2 adjustable auxiliary switches
- Automatic shut-off at end position (overload switch)
- Customized versions available
- Devices meet CE requirement

**Order-examples**

Ball-valve, Bracket and Actuator individual:

**Order-code**

- BAS... or BMS...
- ZAK2
- JV...

Ball-valve with Actuator assembled:

**Order-code**

- JV... + BAS... or BMS...  
(The order-code of the bracket must not be presented)

**Nomenclature/Specification/Technical data**

BAS1N	AC/DC24V	with cable
BAS1.SN	AC/DC24V	with 2 auxiliary switches and cable
BAS2N	AC230V	with cable
BAS2.SN	AC230V	with 2 auxiliary switches and cable

Actuator	BAS1...N	BAS2...N
Torque	8 Nm	8 Nm
Running time OPEN	30 s	30 s
Running time CLOSE	30 s	30 s
Supply voltage	AC/DC24V	AC230V
Frequency	50-60 Hz	50-60 Hz
Power consumption		
- Running	2.5 W	3.0 W
- At end position	0.5 W	0.5 W
Dimensioning	5.0 VA / 3.4 A @ 2 ms	3.6 VA / 0.25 A @ 2 ms
Weight	1.1 kg	1.2 kg
Control signal	2- or 3-point	
Position signal	none	
Angle of rotation/working range	90° (93° mech.)	
Angle of rotation/limitation	none	
Auxiliary switches	3(1.5)A, AC230V	
- S1 setting range	5°...85° < adjustable	
- S2 setting range	5°...85° < adjustable	
Cable	1.0 m halogen-free	
- Motor	3-Wire 1-2-3	
- Switches	5-Wire 21-22-23-24-25	
Lifetime	60'000 Rotations	
Noise level	45 dB (A)	
Protection class	II	
Degree of protection	IP 54	
Mode of action	Type 1	
Ambient conditions		
- Operating temperature	-20...+50°C / IEC 721-3-3	
- Storage temperature	-30...+60°C / IEC 721-3-2	
- Humidity	5...95% r.F. no condensed	
Service	Maintenance-free	
Standards	Mechanics	EN 60 529 / EN 60 730-2-14
	Electronics	EN 60 730-2-14
	EMC Emissions	EN 50 081-1:92 / IEC 61 000-6-3:96
	EMC Immunity	EN 50 082-2:95 / IEC 61 000-6-2:99

### Wiring diagram

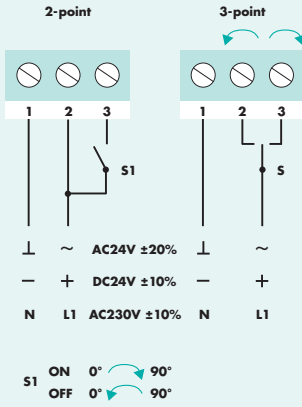

### Changing the direction of rotation

The direction of rotation can be changed by reversing plug **c**.

Factory setting

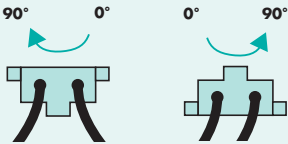

### Auxiliary switches (S)

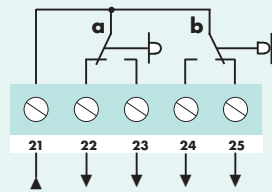

3(1.5)A, AC230V  
Actuator at 0° position

### Dimensions in mm

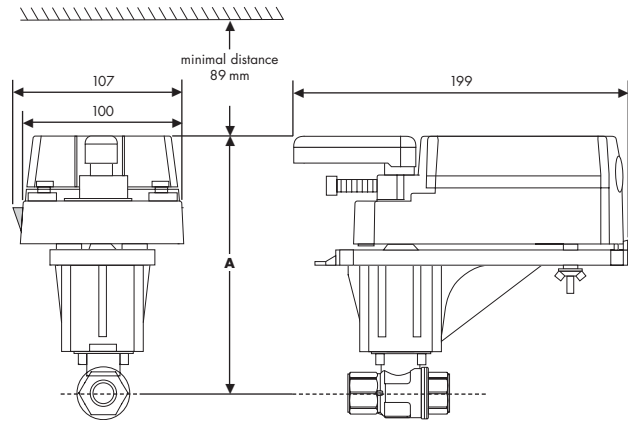
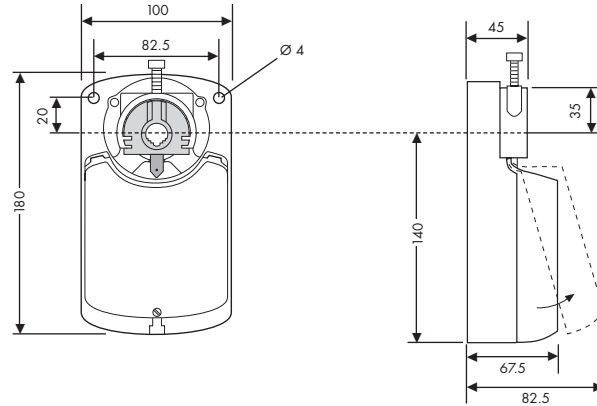

Typ	A
DN15	160
DN20	160
DN25	162
DN32	173
DN40	177
DN50	182

### Setting the auxiliary switches

Factory setting

Switch **a** at 10°  
Switch **b** at 80°

The switching position can be manually changed to any required position by turning the ratchet.

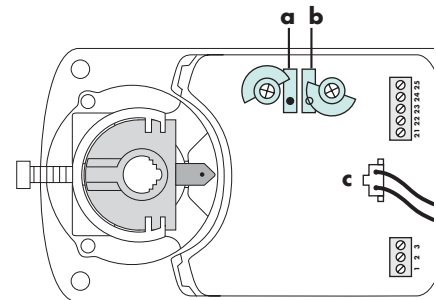

### Assembly table

